

Mark	Revised record	Date
△		

### Specifications

Model	Voltage (V)	Frequency (Hz)	Speed	Power Consumption (W)	Airflow (m³/h)		Sound (dB)	Weight (kg)
					0 Pa			
FR-CL1890V	220 230 240	50	HH	155	600	—	54	28
			Hi	62	—	420	46	
			Mid	48	380	—	44	
			Low	30	300	—	38	
			LL	20	250	—	32	

Motor type	8 Pole DC brushless motor	Insulation resistance: Over 10MΩ (500V megger)	Withstanding voltage	AC1000V for 1 min	Insulation class	E
------------	---------------------------	--	----------------------	-------------------	------------------	---

Airflow measured by JIS C9603 chamber method  
(At 80Pa: maximum power consumption 159W)

### Major Parts

No.	Parts	Material	Finish	Color
1	Hood body	Galvanized steel	Oil repelling painting	Refer to column
2	Oil panel	Galvanized steel	Oil repelling painting	Refer to column
3	Rectifier baffle panel	Galvanized steel	Oil repelling painting	Refer to column
4	Blower unit	Galvanized steel		
5	Motor(For fan)	8 Pole DC brushless motor, class E		
6	Motor(For disk)	8 Pole DC brushless motor, class E		
7	Fan	Galvanized steel(Sirocco fan)		
8	disk	Stainless steel	Double sided hydrophilic painting (One touch attachment and detachment)	
9	Switch	Soft touch switch	Operation on/off, Air flow(Low/Mid/Hi), Timer(3min), Lamp, cleaning lamp, 24 hour mode	
10	Exhaust port	Galvanized steel	Shutter is attached.	*Accessories
11	Oil tray	Galvanized steel	Oil repelling painting	Refer to column
12	Power supply cord	cable cable(Without a plug)		
13	Lighting	LED(Day white color, 3.5W)		
14	Duct cover fixing bracket	Galvanized steel		*Accessories
15	Duct cover	Galvanized steel	Oil repelling painting	Refer to column *Accessories
16	Slide duct cover	Galvanized steel	Oil repelling painting	Refer to column *Accessories

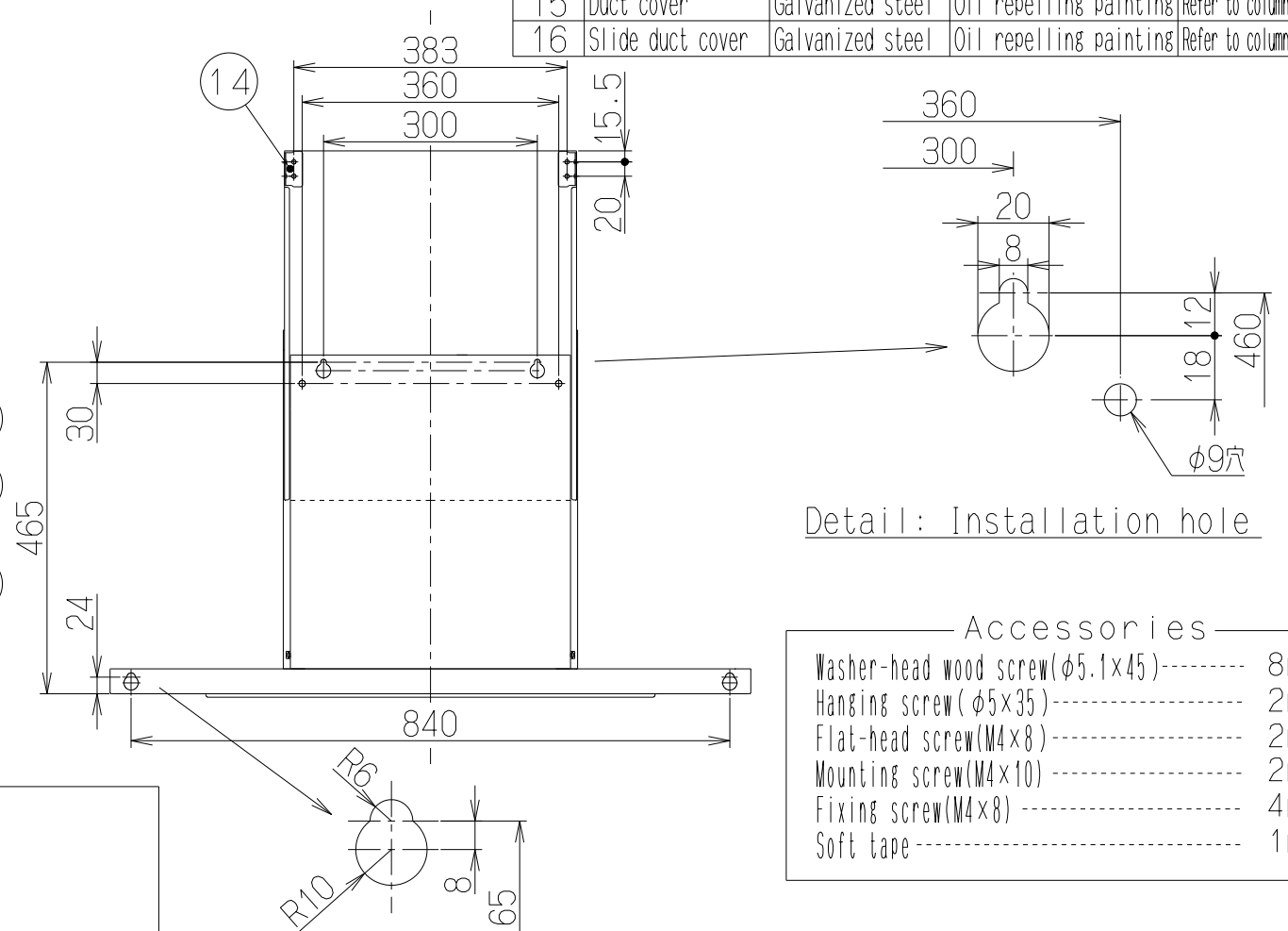
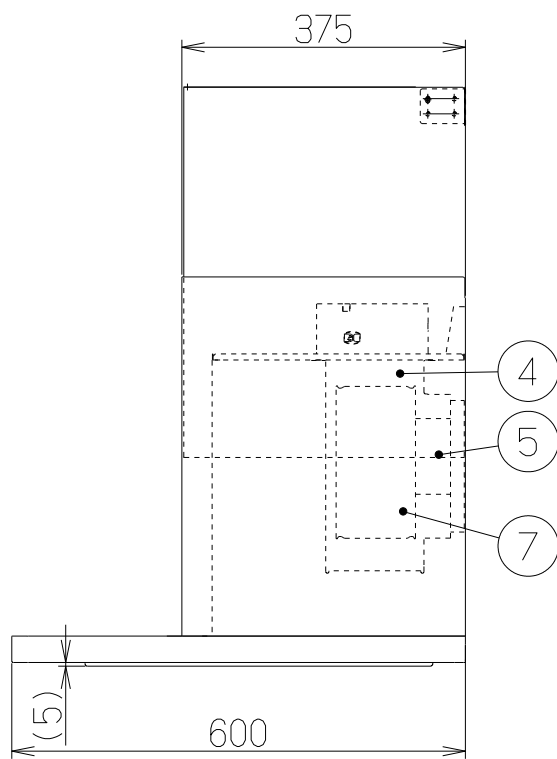
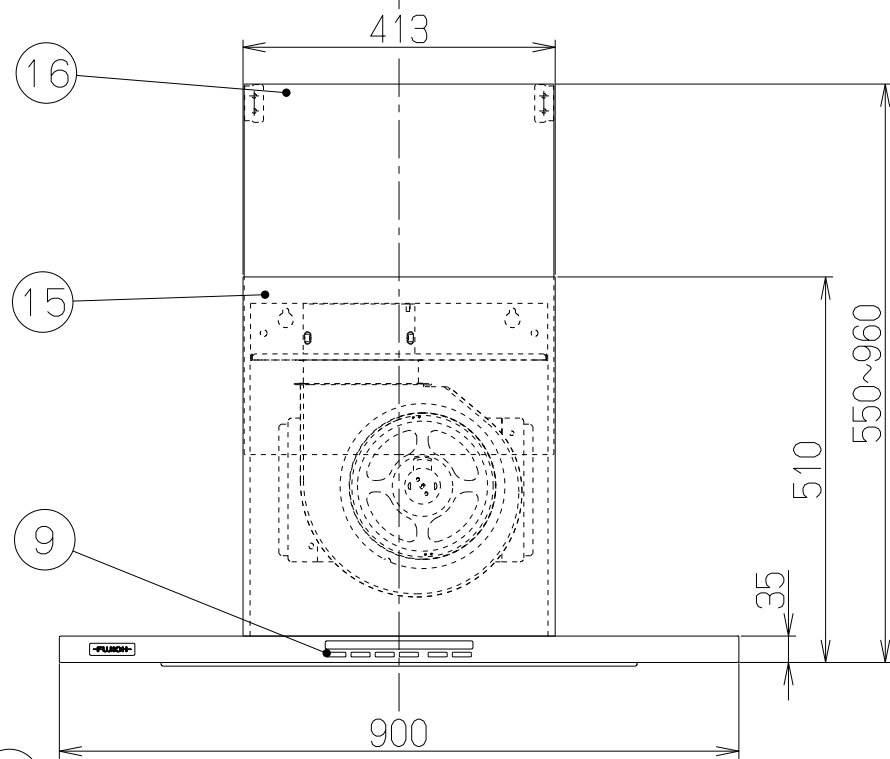
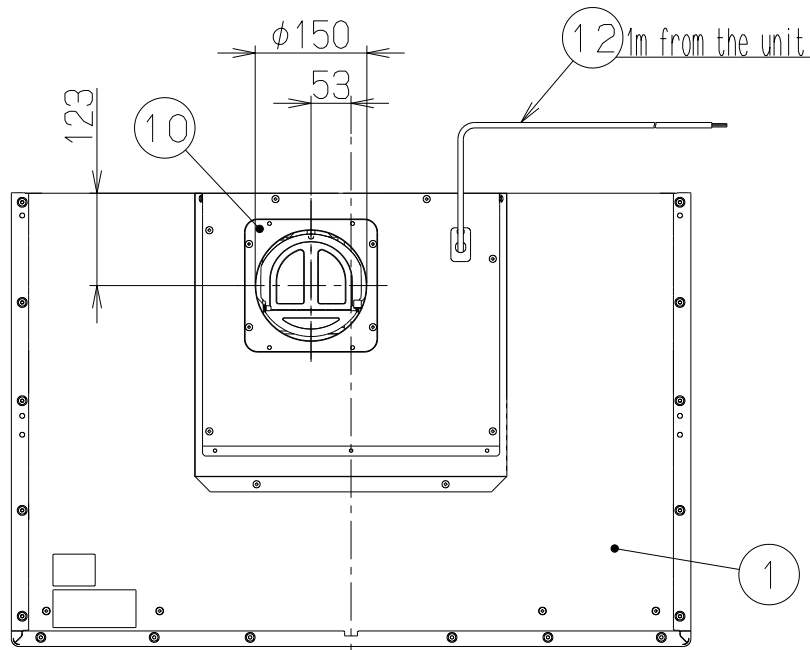

Detail: Installation hole

Accessories	
Washer-head wood screw(φ5.1x45)	8pcs
Hanging screw(φ5x35)	2pcs
Flat-head screw(M4x8)	2pcs
Mounting screw(M4x10)	2pcs
Fixing screw(M4x8)	4pcs
Soft tape	1pcs

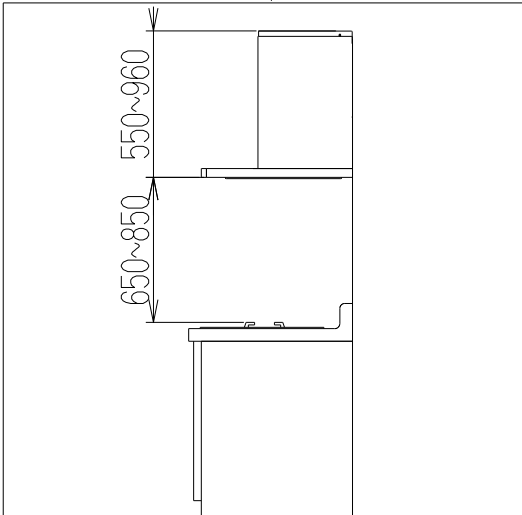
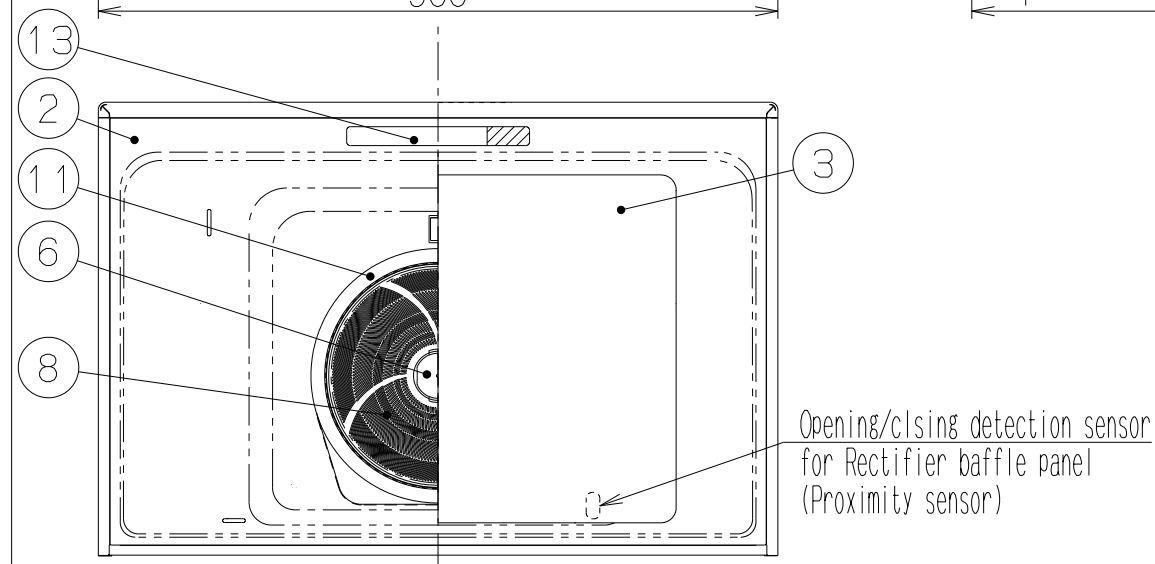

Standard Installation

Detail: Installation hole

FR-CL1890V W	1F9093XP	White	—
FR-CL1890V RS	1F9093AJ	Rich silver	—
FR-CL1890V SV	1F9093AC	MD Silver	—
Model	Product code	Color	Note
Created date	20/ 2/2017	Product category	Cooker Hood
Updated date	18/10/2022	Model	FR-CL1890V
FUJI INDUSTRIAL CO., LTD.	Scale	1/10	Product outline drawing

Mark	Revised record	Date
△		

### Specifications

Model	Voltage (V)	Frequency (Hz)	Speed	Power Consumption (W)	Airflow (m <sup>3</sup> /h)		Sound (dB)	Weight (kg)
					0 Pa			
FR-CL1890R	220	50	HH	140	520	—	57	31
			Hi	94	420	—	54	
			Mid	69	380	—	51	
			Low	39	300	—	44	
			LL	25	250	—	40	
	230	50	HH	150	535	—	57	
			Hi	94	420	—	54	
			Mid	69	380	—	51	
			Low	39	300	—	44	
			LL	25	250	—	40	
	240	50	HH	160	550	—	57	
			Hi	94	420	—	54	
			Mid	69	380	—	51	
			Low	39	300	—	44	
			LL	25	250	—	40	

Motor type	8 Pole DC brushless motor	Insulation: Over 10MΩ resistance:(500V megger)	Withstanding voltage	AC1000V for 1 min	Insulation class	E
------------	---------------------------	--	----------------------	-------------------	------------------	---

Airflow measured by JIS C9603 chamber method (At 80Pa: maximum power consumption 159W)

### Major Parts

No.	Parts	Material	Finish	Color
1	Hood body	Galvanized steel	Oil repelling painting	Refer to column
2	Oil panel	Galvanized steel	Oil repelling painting	Refer to column
3	Rectifier baffle panel	Galvanized steel	Oil repelling painting	Refer to column
4	Blower unit	Galvanized steel		
5	Motor(For fan)	8 Pole DC brushless motor,class E		
6	Motor(For disk)	8 Pole DC brushless motor,class E		
7	Fan	Galvanized steel(Sirocco fan)		
8	disk	Stainless steel	Double sided hydrophilic painting (One touch attachment and detachment)	
9	Switch	Soft touch switch	Operation on/off,Air flow(Low/Mid/Hi),Timer(3min),Lamp,cleaning lamp,24 hour mode	
10	Oil tray	Galvanized steel	Oil repelling painting	Refer to column
11	Power supply cord	cable cable(Without a plug)		
12	Lighting	LED(Day white color,3.5W)		
13	Duct cover	Galvanized steel	Oil repelling painting	Refer to column *Accessories
14	Recycling device	Galvanized steel		*Accessories
15	Exhaust adapter	Galvanized steel		*Accessories
16	Exhaust box	Galvanized steel		*Accessories
17				
18	Slide duct cover	Galvanized steel	Oil repelling painting	Refer to column *Accessories
19				
20	Duct cover fixing bracket	Galvanized steel		*Accessories

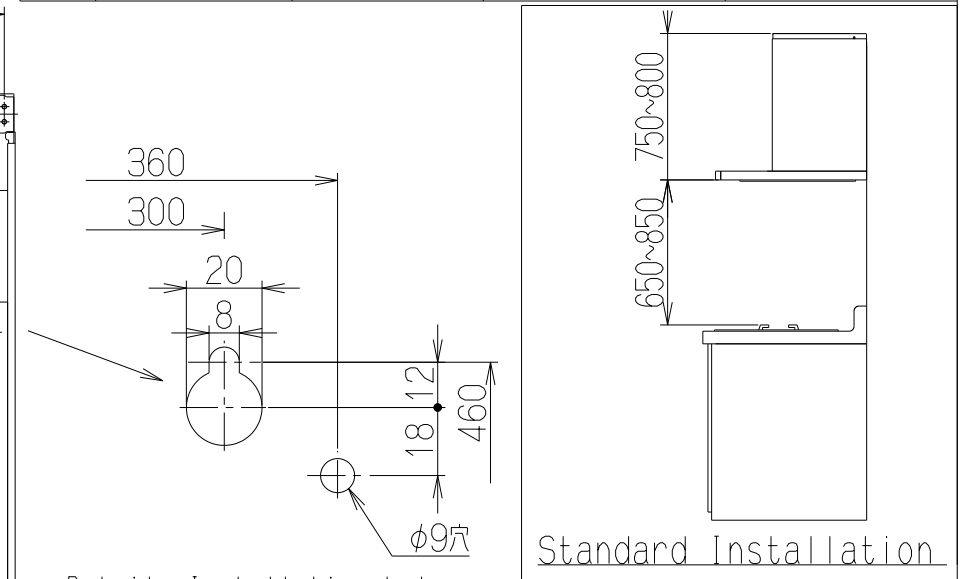
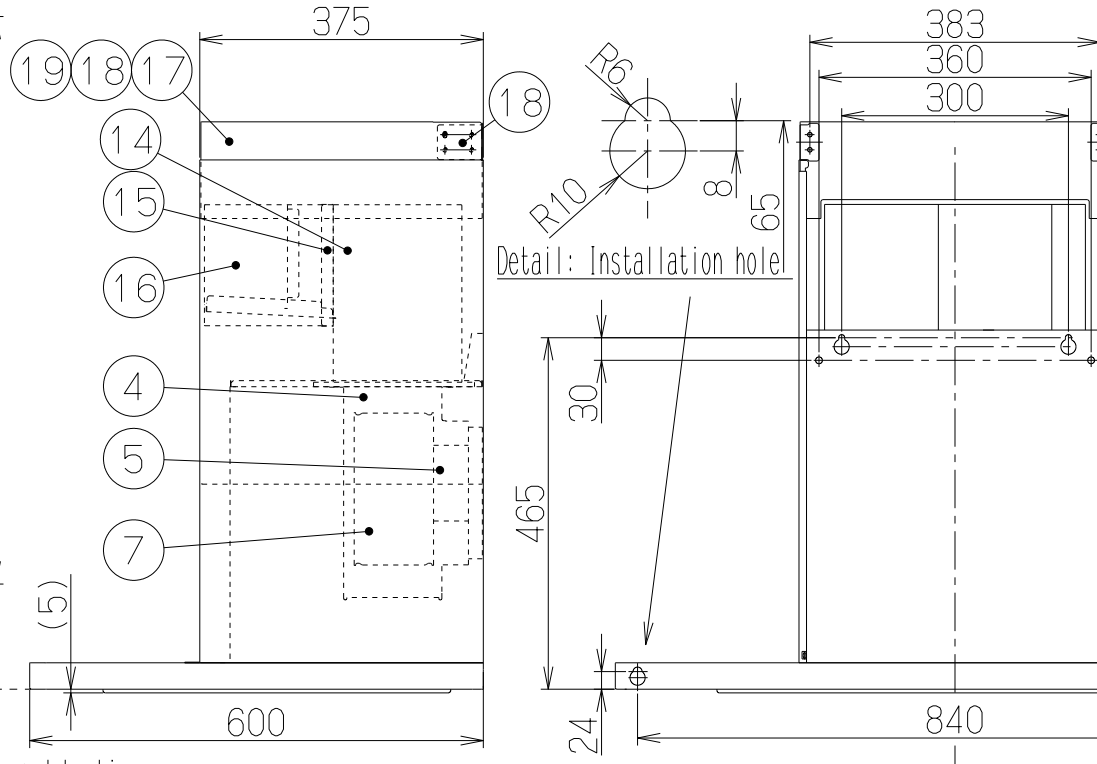
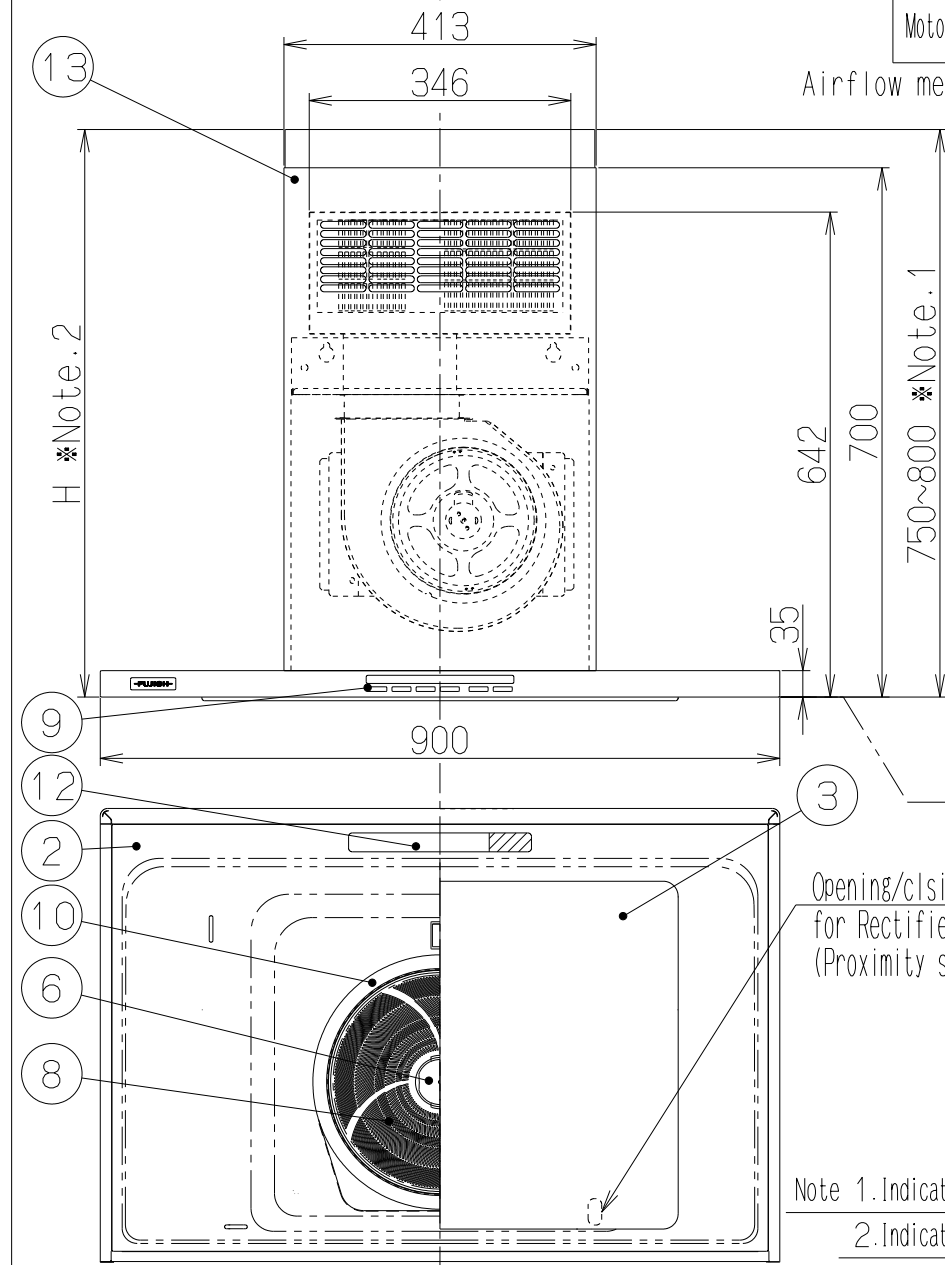
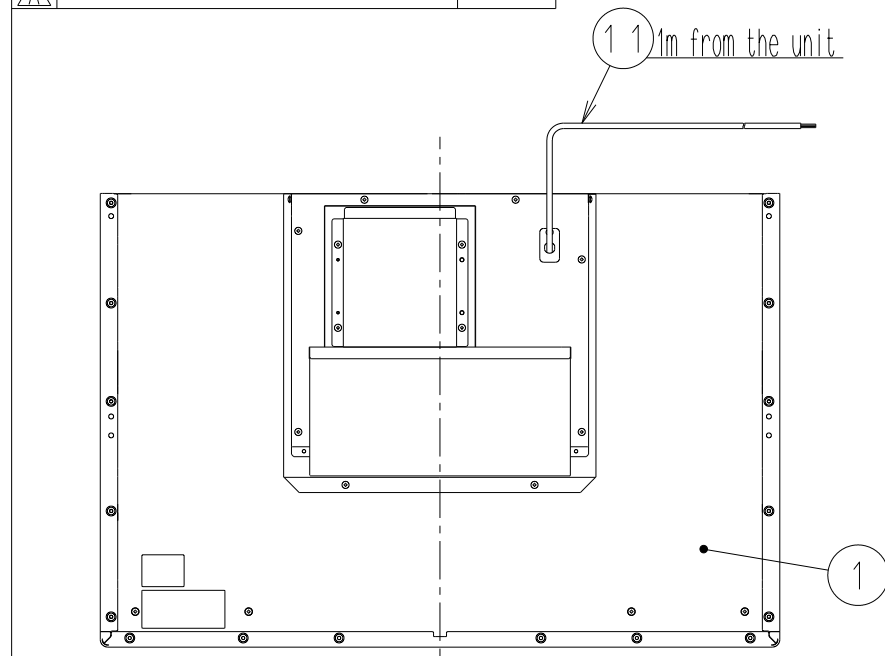

Accessories	
Washer-head wood screw(φ5.1x45)	8pcs
Hanging screw(φ5x35)	2pcs
Flat-head screw(M4x8)	2pcs
Mounting screw(M4x10)	2pcs
Fixing screw(M4x8)	14pcs

Slide range dimension list		
No.	Model	H dimension
⑱	FR-CL18-DCT85*	800~850
⑲	FR-CL18-DCT90*	850~900

Color code is entered in "\*" of model name.

Note 1.Indicates the sliding range of the accessory sliding duct cover.  
 2.Indicates the slide range of the optional slide duct cover.(See slide range demension list)  
 In addition,the dimensions of the optional slide duct vary depending on the model.

Model	Product code	Color	Note
FR-CL1890R W	1F9094XP	White	—
FR-CL1890R RS	1F9094AJ	Rich silver	—
FR-CL1890R SV	1F9094AC	MD Silver	—

Created date	20/ 2/2017	Product category	Cooker Hood
Updated date	18/10/2022	Model	FR-CL1890R
FUJI INDUSTRIAL CO., LTD.	Scale 1/10	Product outline drawing	