

# WATER HEATER/ FZ-WH50

## INSTANT SERIES

A hassle-free water heater  
さざ波シリーズ

Manufactured to enable personal control of the shower temperature by a turn of the control while allowing you to beat the unbearable climate swings.

Enjoy quieter operation, powerful flow and experience a new degree of comfort while showering. Your shower experience will never be the same!

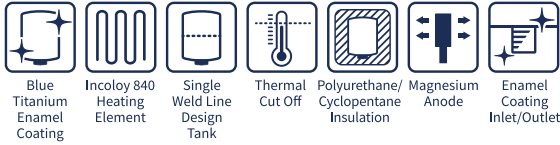

**5** YEARS  
WATER HEATER  
LIMITED WARRANTY\*



## FEATURES

### 01/ Performance



**90° Stop Valve with Built-in Filter**

Enjoy higher water flow rate and cleaner water



**Stepless Power Control**

Shower at your ideal shower temperature



**Powerful Flow#**

Deliver powerful flow yet save up to 70% energy



**Quieter Operation#**

Quieter operation using DC pump versus AC pump



**Maintenance-free with Brushless Design#**

No carbon brush to change and enjoy cleaner water

(\*For models with Brushless DC Silent Inverter Pump only)

### 02/ Safety



**Fire Retardant Heater Tank**

Peace of mind with UL-94 compliant fire retardant VO material



**Double Function Thermostat**

Auto reset thermostat when water temperature exceeds safe limit



**IP25 Splash Proof Protection**

Protect against water and dust



**Auto Flow Sensor Switch**

Auto cut-off when water flow is too low to avoid dry burn



**Anti-Leak Water Tank**

Avoid scalding by withstanding high water pressure

### 03/ Comfort



**180° Swivel Diverter Spout^**

3-in-1 spout with swivelable diverter for extra convenience



**Adjustable Rain Shower Height^**

Extendable by 325mm to bath at your preferred height

(^For models with Rain Shower Set only)

## 5 MULTI SPRAY HANDSHOWER WITH ANTI-TWIST HOSE

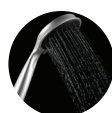

01/ Comfort



02/ Maxi

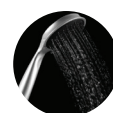

03/ Combo

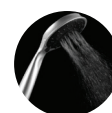

04/ Misty



05/ Massage

\*5 years warranty for tank • 1 year warranty for other parts  
Warranty Terms and Conditions apply

## COLORS

### 01/ Hand Shower Set Type



**BK/** Black (Matt)



**W/** White (Glossy)

### 02/ Rain Shower Set Type



**BK/** Black (Matt)



**W/** White (Glossy)

Product images are for illustrative purposes only and may differ from the actual product. The dimensions of both types of heaters are identical.

## INSTALLATIONS

### 01/ Hand Shower Set Type

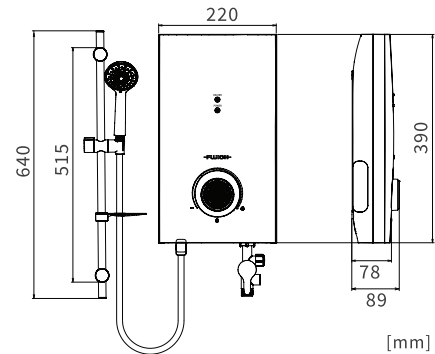

[mm]

### 02/ Rain Shower Set Type

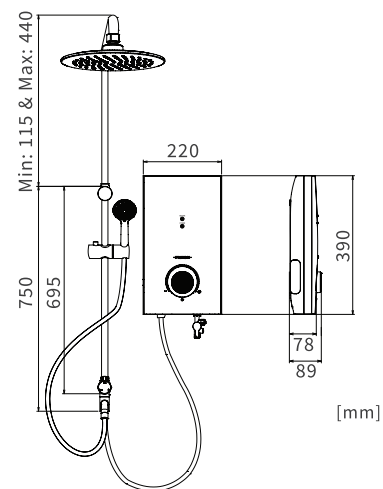

[mm]

## SPECIFICATIONS

Model Name	FZ-WH5033N	FZ-WH5033D	FZ-WH5033NR	FZ-WH5033DR
<b>Equipment</b>				
Water Connection [mm/inch BSP]	15 or 1/2	15 or 1/2	15 or 1/2	15 or 1/2
Brushless DC Silent Inverter Pump	No	Yes	No	Yes
180° Swivel Divert Spout	No	No	Yes	Yes
Adjustable Rain Shower Height	No	No	Yes	Yes
<b>Performance</b>				
Minimum Water Flow Rate [Liter/min]	2	2	2	2
Maximum Water Pressure [kPa]	380	380	380	380
Minimum Water Pressure [kPa]	20	20	20	20
<b>Power, Voltage</b>				
Voltage [V/Hz]	230/50	230/50	230/50	230/50
Available Power [kW]	3.3	3.3	3.3	3.3
<b>Accreditation</b>				
Safety Standard	IEC	IEC	IEC	IEC
ROSH	ROSH COMPLIANT	ROSH COMPLIANT	ROSH COMPLIANT	ROSH COMPLIANT
ISO Certified Manufacturer	ISO 9001:2015	ISO 9001:2015	ISO 9001:2015	ISO 9001:2015
<b>Dimensions and Weight</b>				
Dimensions of Heater [mm]	W220 x H390 x D89	W220 x H390 x D89	W220 x H390 x D89	W220 x H390 x D89
Net Weight(Heater only) [kg]	1.3	1.6	1.3	1.6
Gross Weight(Heater+Shower Set only) [kg]	2.6	2.9	4.5	4.8

