

OVEN

FV-EL62



1 OVEN
LIMITED WARRANTY*

The All-Around Dream Oven

多才なオーブンを味方に、暮らしを楽に。

Say goodbye to scrubbing grime off your oven. FV-EL62 pyrolytic self-clean feature will torch away any residues or grease for a swift cleaning experience. The heat shield coating can withstand high temperature up to 445°C. A safe and reliable choice for any kitchen with its 4-layered glass door and 14 functions. This oven is as multipurpose as it is fiery!

The perfect balance of efficiency, convenience and safeness.



ADVANCED FUNCTIONS

01/ Swift & Easy Cleaning with Pyrolytic Self-clean



Raise the inner temperature up to 445°C to incinerate residues and grease for a swift wipe-cleaning experience

02/ Extra Durability with Heat Shield Coating



Special heat-resistant enamel coating protects the oven's internal components from the extreme temperatures

03/ 4-layered Glass Door for Added Safety

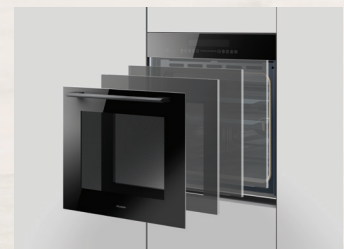

4 toughened glass layers lessen heat on the glass door during usage to avoid burn or shock injuries for a safer kitchen

COLORS



INSTALLATIONS

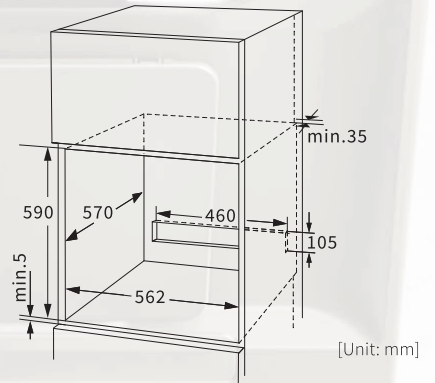
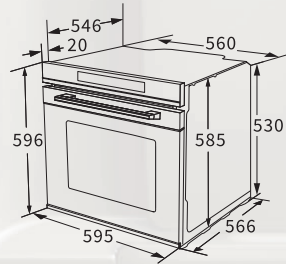

Product images are for illustrative purposes only and may differ from the actual product.

ACCESSORIES



Wire Rack

Enamel Baking Tray

Deep Enamel Baking Tray

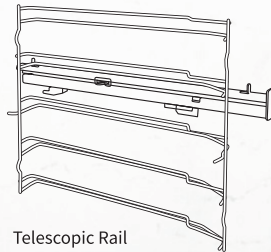

Telescopic Rail

SPECIFICATIONS

| | |
|------------------------------------|---|
| Model Name | FV-EL62 |
| Type | Built-in Electric Oven |
| Gross Dimensions [mm] | W595 x D566 x H596 |
| Cut-out Dimensions [mm] | W562 x D570 x H590 |
| Weight [kg] | 42 |
| Voltage [V/Hz] | 220, 230, 240/50, 60 |
| Rated Power Consumption [W] | 3200 |
| Ampere required [A](Based on 240V) | 15 |
| Temperature Range [°C] | 30-250 |
| No. of Layers of Glass Door | 4 |
| Display | LED Display |
| Switch | Touch Switch + Slider Control |
| Cavity | Heat Shield Coating |
| No. of Rack Position | 5 |
| Functions | 14 |
| Cavity Capacity [L] | 72 |
| Self-Cleaning | Pyrolytic Self-clean |
| Timer | Yes |
| Set End-time | Yes |
| Child Safety Lock | Yes |
| Accessories | Wire Rack Enamel Baking Tray Deep Enamel Baking Tray Telescopic Rail (1 set) |

FUNCTIONS



CONVENTIONAL

For traditional baking and roasting on one level. Especially suitable for cakes with moist toppings.



CONVECTION

For baking and roasting at one or more levels. Heat comes from the ring heater surrounding the fan evenly.



ECO

For energy-saved cooking.



CONVENTIONAL + FAN

For baking and roasting at one or more levels. The fan distributes the heat from the heating elements evenly around the cavity.



RADIANT HEAT

For grilling small amounts of food and for browning food. Please put the food in the center part under the grill heating.



DOUBLE GRILL + FAN

For grilling flat items and for browning food. The fan distributes the heat evenly around the cavity.



DOUBLE GRILL

For grilling flat items and for browning food.



PIZZA

For pizza and dishes which need a lot of heat from underneath. The bottom heater and ring heater will work.



BOTTOM HEAT

For adding extra browning to the bases of pizzas, pies, and pastries. Heating come from the bottom heater.



DEFROST

For gently defrosting frozen food.



FERMENTATION

For making yeast dough and sourdough to prove and culturing yogurt.



PYROLYTIC SELF-CLEANING

For cleaning cavity by heating it at a high temperature to burn the residues.



SABBATH MODE

With the Sabbath mode, you can set the cooking process for 80 hours, to keep food warm without switching on and off the oven.



QUICK PREHEAT

Use this to have a quick preheat.

